

**CE**  
EN 858-1

**PIA**

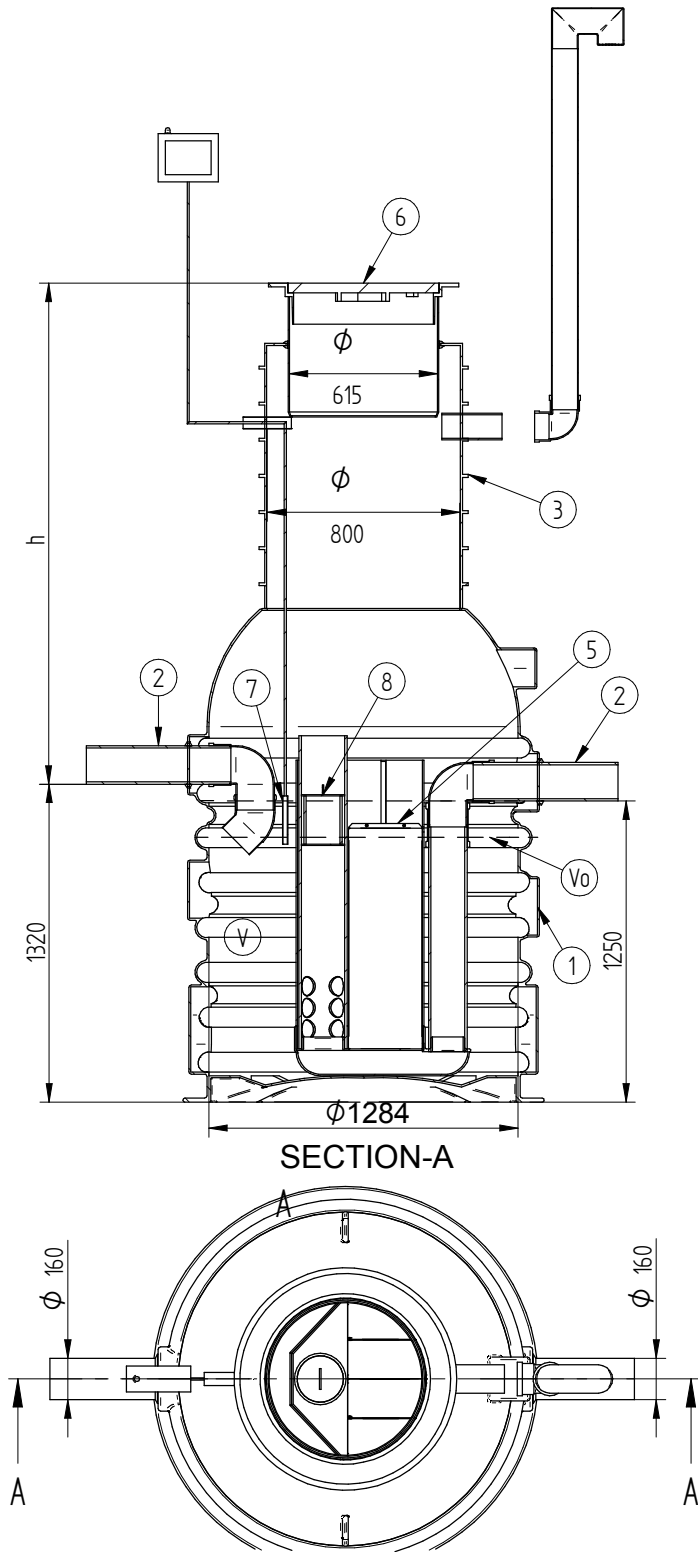

I'd like to order

I'd like a quote

Mark the installation depth of the tank  $h$  (depth from the ground to the bottom of the inlet pipe in mm)  
 $h =$

Notes (name of project or address, special need etc):

No	NAME	MATERIAL	SIZE	Qn/pcs
1	Separators body	PE-HD	D1280,H2000	1
2	Inlet- outlet pipe	PE-HD	D160 mm	1
3	Inspectionwell (choose the right depth)	PE-HD	D600 mm	1
	Installation depth $h$ is measured from inlet pipe bottom to groundlevel in mm. On special occasions we can adapt the body for deeper installation)			
4	Ventilationpipe	PE	D110 mm	1
5	Oil coalescence unit HD Q-PAC			1
V	Whole volume		1600 dm3	
V <sub>o</sub>	Oil layer volume		200 dm3	
ADDITIONAL EQUIPEMENT (Make Your choice)				
6	Telescopic cover D600 mm			
7	Oilseparator alarmunit			
8	Automatic closing valve			

Please send the completed form by e-mail

Please check your selections and measurements before sending

Date	Enjin	Signature	Sheets	OILSEPARATOR I class EQ NS10	
eccua		Mass	Number	RV	